

Ansys 2025/R2

POWERING INNOVATION THAT DRIVES HUMAN ADVANCEMENT

© 2025 ANSYS, Inc. or its affiliated companies
Unauthorized use, distribution, or duplication is prohibited.

Getting Started with Icepak®: Non-Conformal Mesh



ANSYS, Inc.
Southpointe
2600 Ansys Drive
Canonsburg, PA 15317
ansysinfo@ansys.com
<https://www.ansys.com>
(T) 724-746-3304
(F) 724-514-9494

Release 2025 R2
July 2025

ANSYS, Inc. and
ANSYS Europe,
Ltd. are UL
registered ISO
9001:2015 com-
panies.

Copyright and Trademark Information

© 1986-2025 ANSYS, Inc. Unauthorized use, distribution or duplication is prohibited.

ANSYS, Ansys Workbench, AUTODYN, CFX, FLUENT and any and all ANSYS, Inc. brand, product, service and feature names, logos and slogans are registered trademarks or trademarks of ANSYS, Inc. or its subsidiaries located in the United States or other countries. ICM CFD is a trademark used by ANSYS, Inc. under license. All other brand, product, service and feature names or trademarks are the property of their respective owners. FLEXIm and FLEXnet are trademarks of Flexera Software LLC.

Disclaimer Notice

THIS ANSYS SOFTWARE PRODUCT AND PROGRAM DOCUMENTATION INCLUDE TRADE SECRETS AND ARE CONFIDENTIAL AND PROPRIETARY PRODUCTS OF ANSYS, INC., ITS SUBSIDIARIES, OR LICENSORS. The software products and documentation are furnished by ANSYS, Inc., its subsidiaries, or affiliates under a software license agreement that contains provisions concerning non-disclosure, copying, length and nature of use, compliance with exporting laws, warranties, disclaimers, limitations of liability, and remedies, and other provisions. The software products and documentation may be used, disclosed, transferred, or copied only in accordance with the terms and conditions of that software license agreement.

ANSYS, Inc. and ANSYS Europe, Ltd. are UL registered ISO 9001: 2015 companies.

U.S. Government Rights

For U.S. Government users, except as specifically granted by the ANSYS, Inc. software license agreement, the use, duplication, or disclosure by the United States Government is subject to restrictions stated in the ANSYS, Inc. software license agreement and FAR 12.212 (for non-DOD licenses).

Third-Party Software

See the legal information in the product help files for the complete Legal Notice for Ansys proprietary software and third-party software. If you are unable to access the Legal Notice, please contact ANSYS, Inc.

Conventions Used in this Guide

Please take a moment to review how instructions and other useful information are presented in this documentation.

- Procedures are presented as numbered lists. A single bullet indicates that the procedure has only one step.
- Bold type is used for the following:
 - Keyboard entries that should be typed in their entirety exactly as shown. For example, “**copy file1**” means you must type the word **copy**, then type a space, and then type **file1**.
 - On-screen prompts and messages, names of options and text boxes, and menu commands. Menu commands are often separated by greater than signs (>). For example, “click **HFSS > Excitations > Assign > Wave Port.**”
 - Labeled keys on the computer keyboard. For example, “Press **Enter**” means to press the key labeled **Enter**.
- Italic type is used for the following:
 - Emphasis.
 - The titles of publications.
 - Keyboard entries when a name or a variable must be typed in place of the words in italics. For example, “**copy filename**” means you must type the word **copy**, then type a space, and then type the name of the file.
- The plus sign (+) is used between keyboard keys to indicate that you should press the keys at the same time. For example, “Press Shift+F1” means to press the **Shift** key and, while holding it down, press the **F1** key also. You should always depress the modifier key or keys first (for example, Shift, Ctrl, Alt, or Ctrl+Shift), continue to hold it/them down, and then press the last key in the instruction.

Accessing Commands: *Ribbons*, *menu bars*, and *shortcut menus* are three methods that can be used to see what commands are available in the application.

- The *Ribbon* occupies the rectangular area at the top of the application window and contains multiple tabs. Each tab has relevant commands that are organized, grouped, and labeled. An example of a typical user interaction is as follows:

"Click **Draw > Line**"

This instruction means that you should click the **Line** command on the **Draw** ribbon tab. An image of the command icon, or a partial view of the ribbon, is often included with the instruction.

- The *menu bar* (located above the ribbon) is a group of the main commands of an application arranged by category such File, Edit, View, Project, etc. An example of a typical user

interaction is as follows:

"On the **File** menu, click the **Open Examples** command" means you can click the **File** menu and then click **Open Examples** to launch the dialog box.

- Another alternative is to use the *shortcut menu* that appears when you click the right-mouse button. An example of a typical user interaction is as follows:

"Right-click and select **Assign Excitation> Wave Port**" means when you click the right-mouse button with an object face selected, you can execute the excitation commands from the shortcut menu (and the corresponding sub-menus).

Getting Help: Ansys Technical Support

For information about Ansys Technical Support, go to the Ansys corporate Support website, <http://www.ansys.com/Support>. You can also contact your Ansys account manager in order to obtain this information.

All Ansys software files are ASCII text and can be sent conveniently by e-mail. When reporting difficulties, it is extremely helpful to include very specific information about what steps were taken or what stages the simulation reached, including software files as applicable. This allows more rapid and effective debugging.

Help Menu

To access help from the Help menu, click **Help** and select from the menu:

- **[product name] Help** - opens the contents of the help. This help includes the help for the product and its *Getting Started Guides*.
- **[product name] Scripting Help** - opens the contents of the *Scripting Guide*.
- **[product name] Getting Started Guides** - opens a topic that contains links to Getting Started Guides in the help system.

Context-Sensitive Help

To access help from the user interface, press **F1**. The help specific to the active product (design type) opens.

You can press **F1** while the cursor is pointing at a menu command or while a particular dialog box or dialog box tab is open. In this case, the help page associated with the command or open dialog box is displayed automatically.

Table of Contents

Table of Contents	Contents-1
1 - Introduction	1-1
2 - Open the Project and Review the Model	2-1
Launch the Ansys Electronics Desktop	2-1
Set 3D UI Options	2-1
Open the Project	2-2
Review the Model	2-2
3 - Assign Boundary Conditions	3-1
Assign an Opening	3-1
Assign a Grille	3-1
Assign a Source	3-2
4 - Create a Heatsink	4-1
Position the Heatsink	4-1
5 - Generate a Conformal Mesh	5-1
View the Conformal Mesh	5-1
6 - Set Up the Solution	6-1
Create a Monitor Point	6-1
Create a Solution Setup	6-1
Save the Project	6-1
7 - Run the Simulation and Examine the Results	7-1
Run the Conformal Mesh Simulation	7-1
Examine the Results	7-2
8 - Assign a Mesh Region	8-1
9 - Generate a Non-Conformal Mesh	9-1
View the Non-Conformal Mesh	9-1
10 - Run the Simulation and Examine the Results	10-1
Run the Non-Conformal Mesh Simulation	10-1
Examine the Results	10-2

11 - Summary **11-1**

1 - Introduction

This guide examines the effects of using a non-conformal mesh rather than a conformal mesh in a simple pin-fin heat-sink problem. In the guide, you will learn how to:

- Generate a non-conformal mesh and related parameters such as slack values, maximum element sizes, and so on.
- Understand the effects of a non-conformal mesh on total mesh count and results.
- Generate and compare summary reports.
- Apply non-conformal rules and restrictions.

2 - Open the Project and Review the Model

After launching the Ansys Electronics Desktop, create a project, insert an Icepak design, and build the model.

Launch the Ansys Electronics Desktop

A shortcut of the Ansys Electronics Desktop application appears on your desktop once the application is installed.

Set 3D UI Options

Ensure that the new view orientation scheme introduced in release 2024 R1 is not being used, since the instructions and images in this guide are based on the legacy orientation scheme.

1. From the menu bar, click **View > Options**.

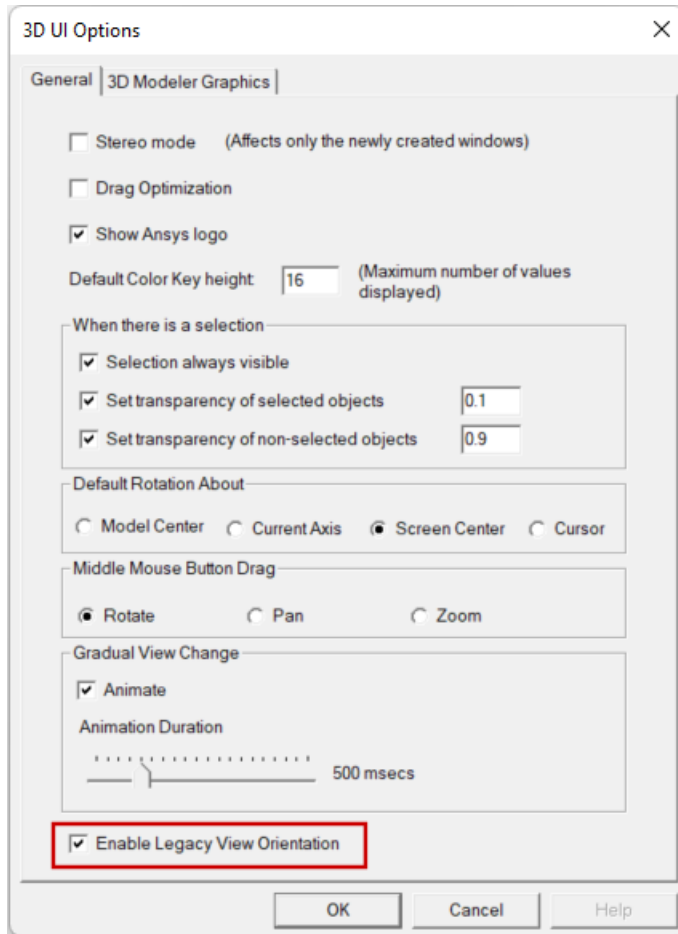

The *3D UI Options* dialog box appears.

2. Ensure that **Enable Legacy View Orientation** is enabled:



3. Click **OK**.

Open the Project

1. On the **Desktop** ribbon tab, click  **Open Examples**. Then:
 - a. In the *Open* dialog box that appears, click the parent folder icon () once to move up one level above the *Examples* folder.
 - b. Double-click the **Help** folder and then the **Icepak** folder.
 - c. Select the file **NonConformalMesh.aedt** and click **Open**.
2. The model is displayed in the **3D Modeler** window.

Review the Model

The model consists of a pin-fin heat sink composed of aluminum, which is in contact with a source dissipating 10 W, as shown below. The source-heatsink assembly sits in the middle of a

wind tunnel with a wind speed of 1.0 m/s. The ambient temperature is 20°C, and the flow regime is turbulent.

The objective of this exercise is to become familiar with the non-conformal meshing methodology and its application. You will examine and compare the solution results of a conformal and a non-conformal mesh.

In Icepak, you can assign mesh regions. First, you define a region around a component. Icepak meshes this region independently of the external global mesh region.

Sample Project - Pin-Fin Heatsink

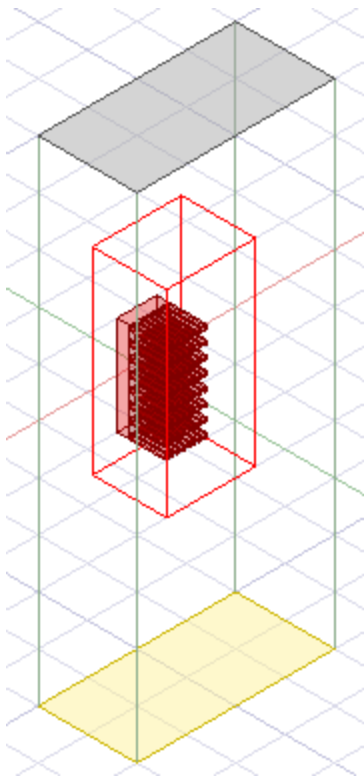

Figure 2-1: Pin-Fin Heatsink

3 - Assign Boundary Conditions

In this model, assign boundary conditions and define thermal and flow properties for an opening, a grille, and a source.

Assign an Opening

1. In the History tree, expand **Model > Sheets > Opening** and select **cabinet_default_side_minz**.
2. In the **3D Modeler** window, right-click and select **Assign Thermal > Opening > Free**.
3. In the **Opening Thermal Model** dialog box under **Flow Specification**, select **Velocity**.
4. For **Z Velocity**, enter **1** and retain **m_per_sec** as the unit.
5. Click **OK**.

Assign a Grille

1. Press **F** to enter face selection mode.
2. In the **3D Modeler** window, select the **cabinet_default_side_maxz** face as shown below.

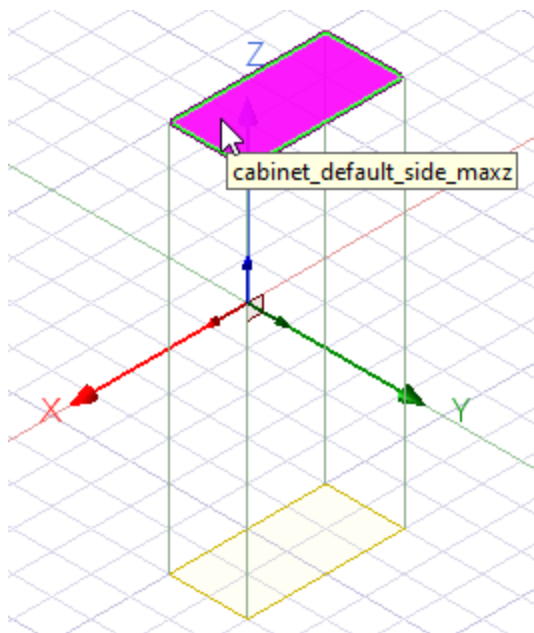

3. Right-click and select **Assign Thermal > Grille**.
4. In the **Grille Thermal Model** dialog box under **Flow Specification**, select **Loss Coefficient** for the **Pressure Loss Type**.
5. For **Free Area Ratio**, enter **0.8**.

6. For **Resistance Type**, select **Perforated Thin Vent**.
7. Click **OK**.

Assign a Source

1. Press **O** to enter object selection mode.
2. In the **3D Modeler** window, with the cursor above the source geometry, click the cabinet and then press **B** to select the geometry behind the cabinet.

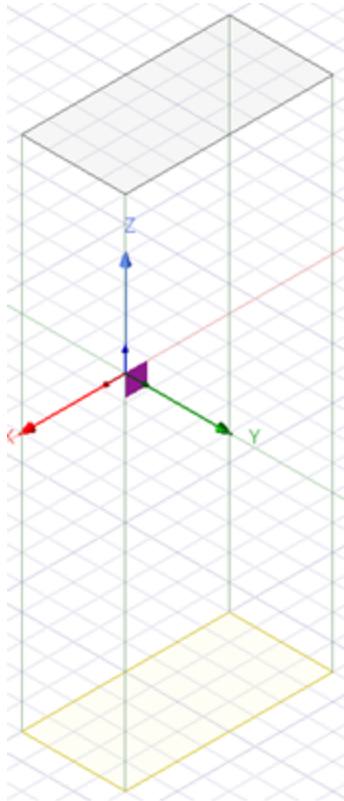

3. Right-click and select **Assign Thermal > Source**.
4. In the **Source Thermal Model** dialog box under **Thermal Specification**, select **Total Power** for the **Thermal Condition**.
5. For **Total Power**, enter **30** and select **W** as the unit.
6. Click **OK**.

4 - Create a Heatsink

Create a heatsink to disperse heat away from the source object.

1. In the **Project Manager**, right-click **3D Components**.
2. From the right-click menu, select **Create > Heatsink**.
3. In the **Heatsink Component** dialog box, click the **Geometry** tab and define the following parameters:
 - **Plane:** ZX
 - **Overall height:** 0.1 meter
4. Under **Base**, define the following parameters:
 - **Length:** 0.2 meter
 - **Width:** 0.08 meter
 - **Height:** 0.02 meter
5. Under **Fin**, define the following parameters:
 - **Type:** CrossCutExtrusion
 - **Flow Direction:** Z
 - **Count (Z):** 8
 - **Count (X):** 8
 - **Thickness (Z):** 0.01 meter
 - **Thickness (X):** 0.004 meter
 - **Offset (Z):** 0 meter
 - **Offset (X):** 0 meter
6. Click the **Properties** tab and review the material assignments for the Heatsink fins and base. Al-Extruded is the assigned solid material, and Steel-oxidised-surface is the assigned surface material.
7. Click **OK**.

Position the Heatsink

1. If not already selected, select the heatsink in the **Project Manager** under **3D Components**.
2. From the **Edit** menu, select **Arrange > Move**.
3. Press the **F4** key to display the **Move** dialog box.
4. In the **Move** dialog box, enter **0.5 ,0.5 ,0.5 meter** for the **Move Vector Value** and **Unit**.

5. Click **OK**.

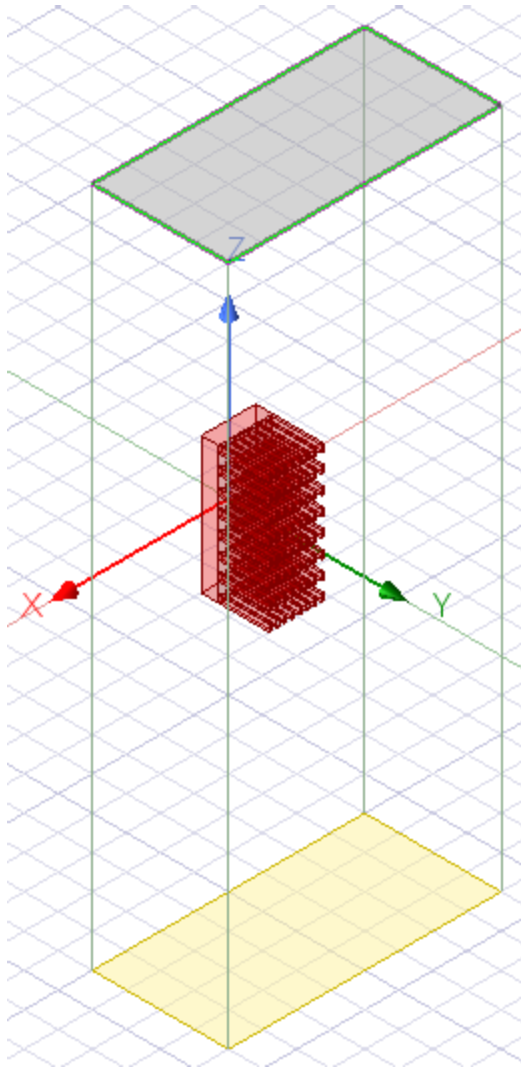

5 - Generate a Conformal Mesh

Generate a conformal mesh for the model.

1. On the **Simulation** ribbon tab, click **Global Mesh Settings**.
2. In the **Mesh Region** dialog box, click the **Advanced** tab.
3. Enable **User specified** and define the global mesh settings as displayed in the image below.

The screenshot shows the 'Advanced' tab of the 'Mesh Region' dialog box. The 'User specified' checkbox is checked. The 'Maximum Element Size' section has three input fields: X (0.02), Y (0.01), and Z (0.05), all with 'meter' as the unit. The 'Minimum Gap' section has three input fields: X (0.0004), Y (0.001), and Z (0.001), all with 'meter' as the unit. The 'Mesh Parameters' section includes: 'Min. elements in gap' (3), 'Min. elements on edge' (2), 'Max size ratio' (2), 'No O-Grids' (unchecked), 'Allow stair-stepped meshing' (unchecked), and 'Enable min. gap override' (checked). The 'Multi level meshing' section includes: 'Enable' (unchecked), 'Max. Levels' (2), 'Buffer Layers' (0), 'Enforce MLM in all objects' (unchecked), and 'Uniform mesh parameters' (unchecked).

4. Click **OK**.
5. On the **Simulation** ribbon tab, click **Generate Mesh**. After the mesh is generated, the **Mesh Visualization** dialog box appears.

View the Conformal Mesh

1. On the **View** ribbon tab, click the **Orient** drop-down list and select **Front**.
2. In the **Mesh Visualization** dialog box under **Mesh display on**, enable **Show**.

3. Under **Plane Location**, select **Y plane through center** for **Define plane**.

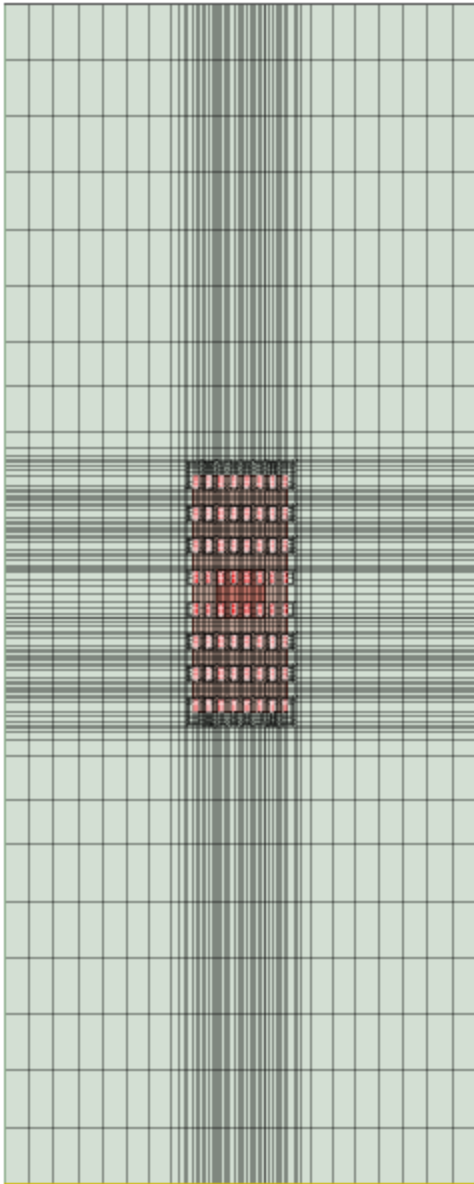

4. Click **Close**.

6 - Set Up the Solution

Create a monitor point for the source and define the solution settings.

Create a Monitor Point

1. In the **Project Manager** under **Thermal**, right-click **Source1** and select **Select Assignment**.
2. In the **3D Modeler** window, right-click and select **Assign Monitor > Point**.
3. In the **Monitor Setup** dialog box, expand **Thermal** and select **Temperature**.
4. Click **OK**.

Create a Solution Setup

1. In the **Project Manager**, right-click **Analysis** and select **Add Solution Setup**.
2. On the **Icepak Solve Setup** dialog box **General** tab, enter **300** for the **Maximum Number of Iterations**.
3. Under **Flow Regime**, select **Turbulent**.
4. Click **Options** to open the **Turbulent Flow Model** dialog box.
5. Select **Zero Equation** and click **OK**.
6. On the **Solver Settings** tab, enter **1 m_per_sec** for **Z Velocity** to speed up the convergence by initializing the solver.
7. Click **Advanced Options** to open the **Advanced Solver Settings** dialog box.
8. Enter the following **Under-relaxation** values:
 - **Pressure**: 0.7
 - **Momentum**: 0.3
 - **Temperature**: 1
9. Click **OK** to close the **Advanced Solver Settings** dialog box.
10. Click **OK** to close **Icepak Solve Setup** dialog box.

Save the Project

From the **File** menu, select **Save**.

7 - Run the Simulation and Examine the Results

Run the Conformal Mesh Simulation

1. In the **Project Manager**, expand **Analysis**.
2. Right-click **Setup1** and select **Analyze**.
3. Right-click **Setup1** and select **Residual** to monitor the simulation while the solver runs.

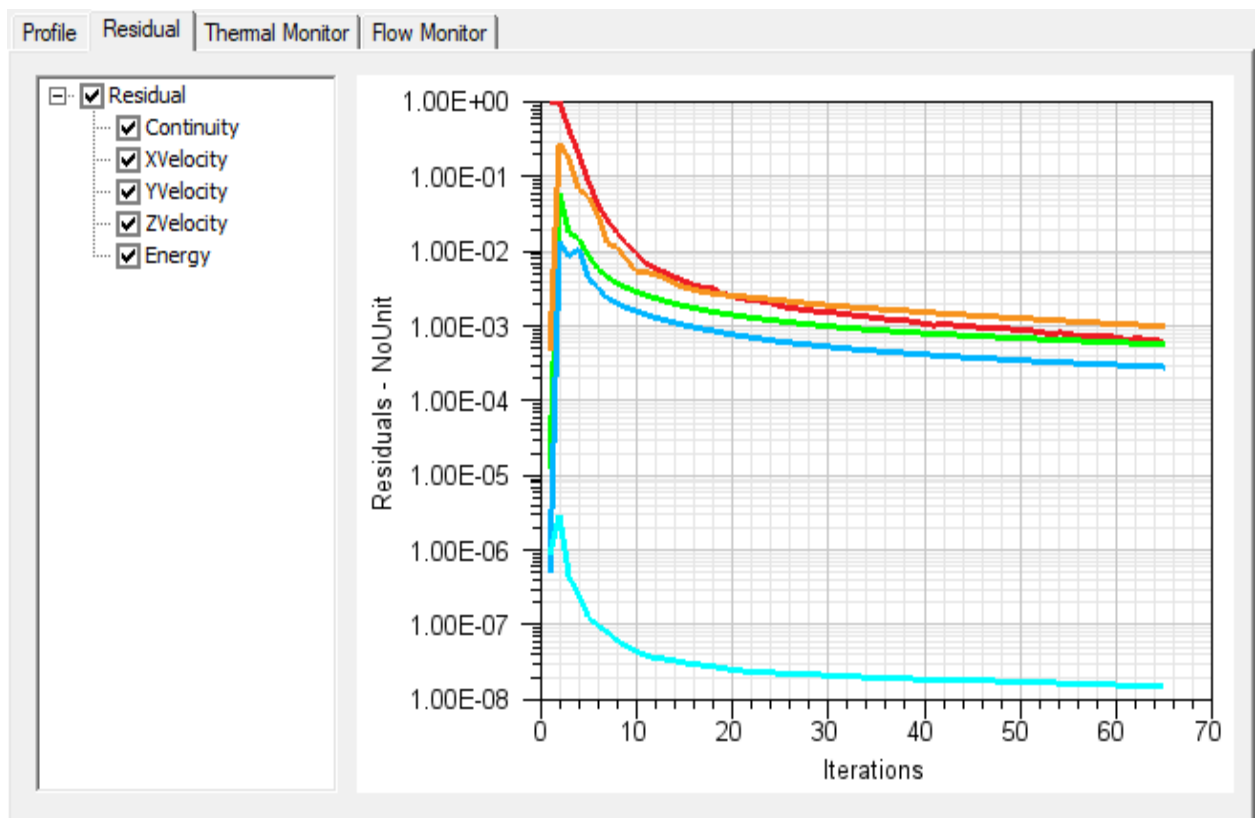

4. Click the **Thermal Monitor** tab to view the temperature data for the monitor point on the

source.

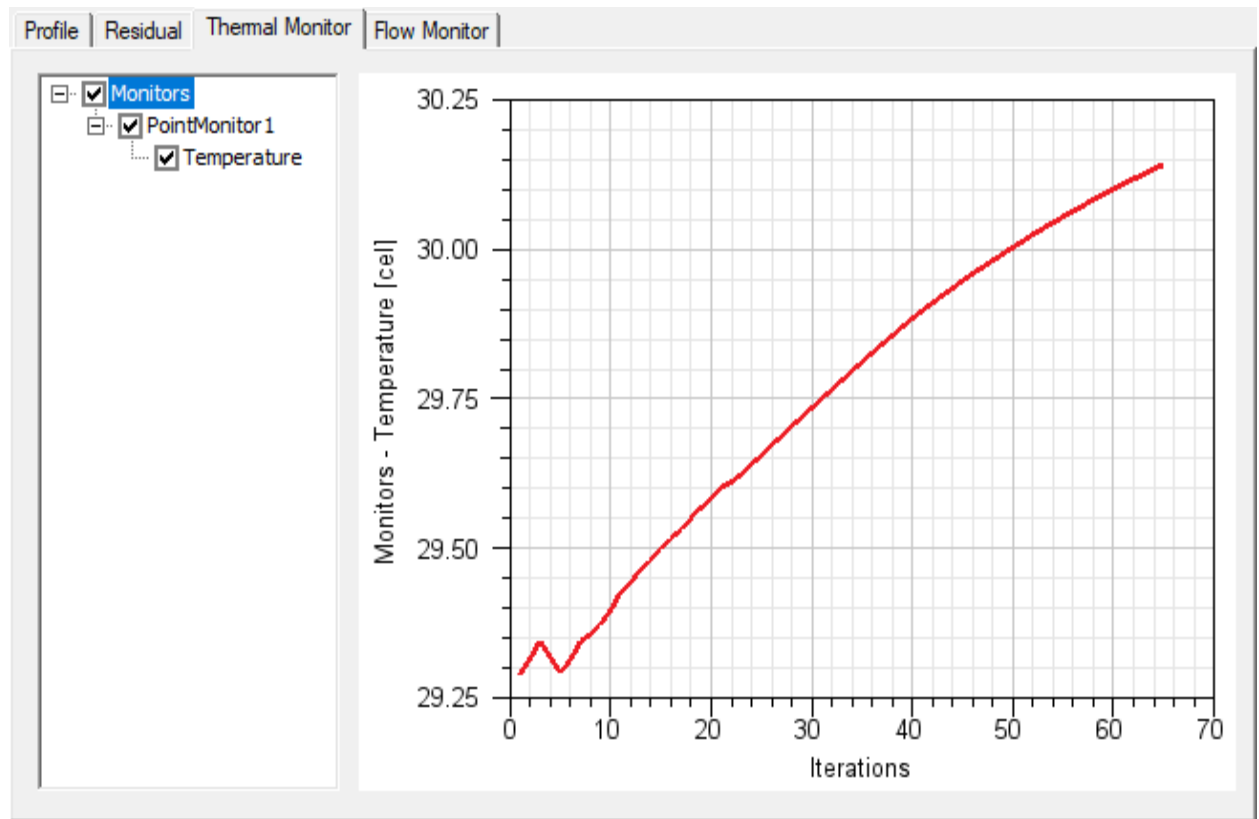

Examine the Results

Create a Fields Summary report to view the thermal data for the source and heatsink.

1. On the **Results** ribbon tab, click **Fields Summary**.
2. In the **Setup Calculation** dialog box, select **Object** for the **Entity Type**.
3. Report the temperature data for the source :
 - Under **Entity**, select **source_1**.
 - Under **Quantity**, select **Temperature**.
 - Click **Add As Single Calculation**.
4. Report the temperature data for the heatsink :
 - Under **Entity**, select all of the heatsink objects.
 - Under **Quantity**, select **Temperature**.
 - Click **Add As Single Calculation**.
5. In the **Fields Summary** dialog box, minimum, maximum, and mean temperatures for the

heat sink and source are displayed. Note the maximum temperature for both objects.

Fields Summary: NonConformalMesh - Non-ConformalMesh

Inputs

Solution: Setup1 : SteadyState

Design Variation: Nominal

Calculations:

Entity Type	Geometry Type	Entity	Quantity	Side	Normal	Mesh	Min	Max	Mean	Stdev	Area/Volume	
Object	Surface	source_1	Temperature[C]	Default	-0.00,1.00,-0.00	Reduced	29.1204	30.1414	9.7407	0.242326	0.0016 m ²	Setup...
Object	Surface	Heatsink1_Base,Heatsink1_...	Temperature[C]	Default		Reduced	22.7888	29.9361	7.0327	1.06817	0.18752 m ²	Delete

Apply and Export... OK Cancel

Clear All

8 - Assign a Mesh Region

Create a mesh region surrounding the source object and heatsink to create a non-conformal mesh.

1. In the History tree, expand **Model > assembly_1 > Sheets > Source** and select **source_1**.
2. Expand **Model > Heatsink1**.
3. Hold **Ctrl** and select **Heatsink1_1**.
4. In the **3D Modeler** window, right-click and select **Assign Mesh Region**.
5. On the **SubRegion** dialog box, select **Pad individual directions** for **Padding Data**.
6. For each **Direction**, select **Absolute Offset** from the **Padding type** drop-down and enter the following values.
 - **+X**: 0.05 meter
 - **-X**: 0.05 meter
 - **+Y**: 0.05 meter
 - **-Y**: 0 meter
 - **+Z**: 0.15 meter
 - **-Z**: 0.05 meter
7. On the **Mesh Region** dialog box **Advanced** tab, enable **User specified**. Under **Maximum Element Size**, enter the following values:
 - **X**: 0.01 meter
 - **Y**: 0.01 meter
 - **Z**: 0.25 meter
8. Under **Minimum Gap**, enter the following values:
 - **X**: 8.9e-05 meter
 - **Y**: 8.9e-05 meter
 - **Z**: 5e-06 meter
9. Under **Multi level meshing**:
 - Disable **Enable**.
 - Disable **Uniform mesh parameters**.

10. Click **OK**.

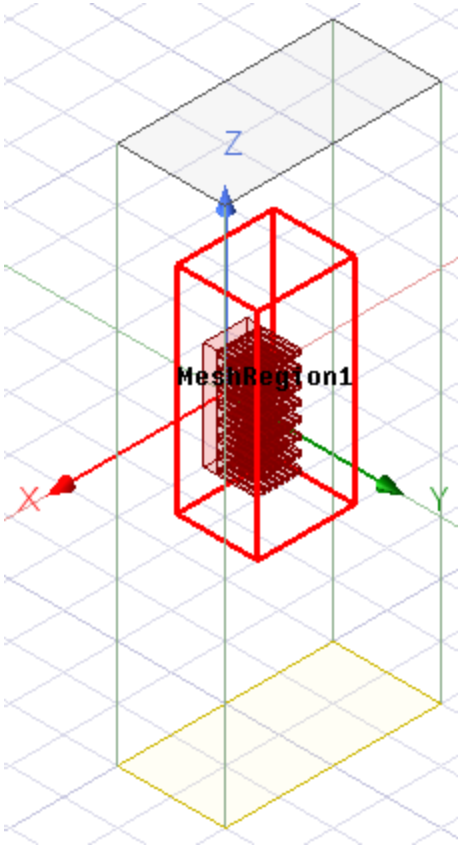

9 - Generate a Non-Conformal Mesh

With the mesh region created, generate a non-conformal mesh for the model. On the **Simulation** ribbon tab, click **Generate Mesh**. After the mesh is generated, the **Mesh Visualization** dialog box appears.

View the Non-Conformal Mesh

1. On the **View** ribbon tab, click the **Orient** drop-down list and select **Front**.
2. In the **Mesh Visualization** dialog box under **Mesh display on**, enable **Show**.
3. Under **Plane Location**, select **Y plane through center** for **Define plane**. Note the clustered mesh lines extending from the heat sink all the way across the domain in both the and directions only within the bounds of the mesh region.

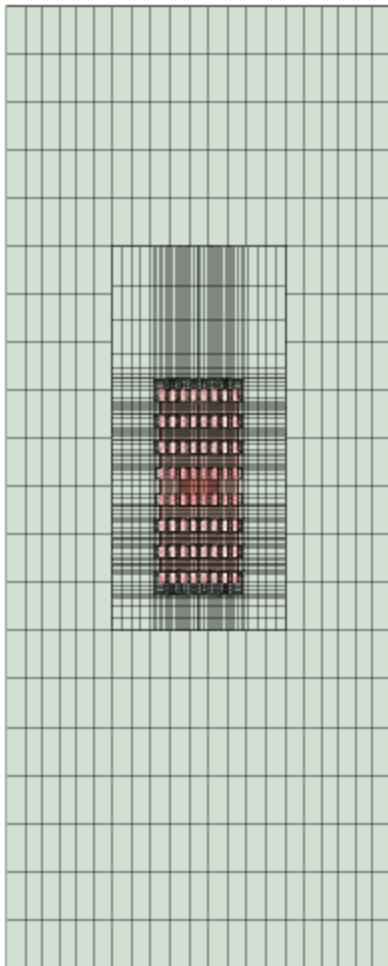

4. Click **Close**.

10 - Run the Simulation and Examine the Results

Run the Non-Conformal Mesh Simulation

1. In the **Project Manager**, expand **Analysis**.
2. Right-click **Setup1** and select **Analyze**.
3. Right-click **Setup1** and select **Residual** to monitor the simulation while the solver runs. With the non-conformal mesh, the simulation converges in fewer iterations.

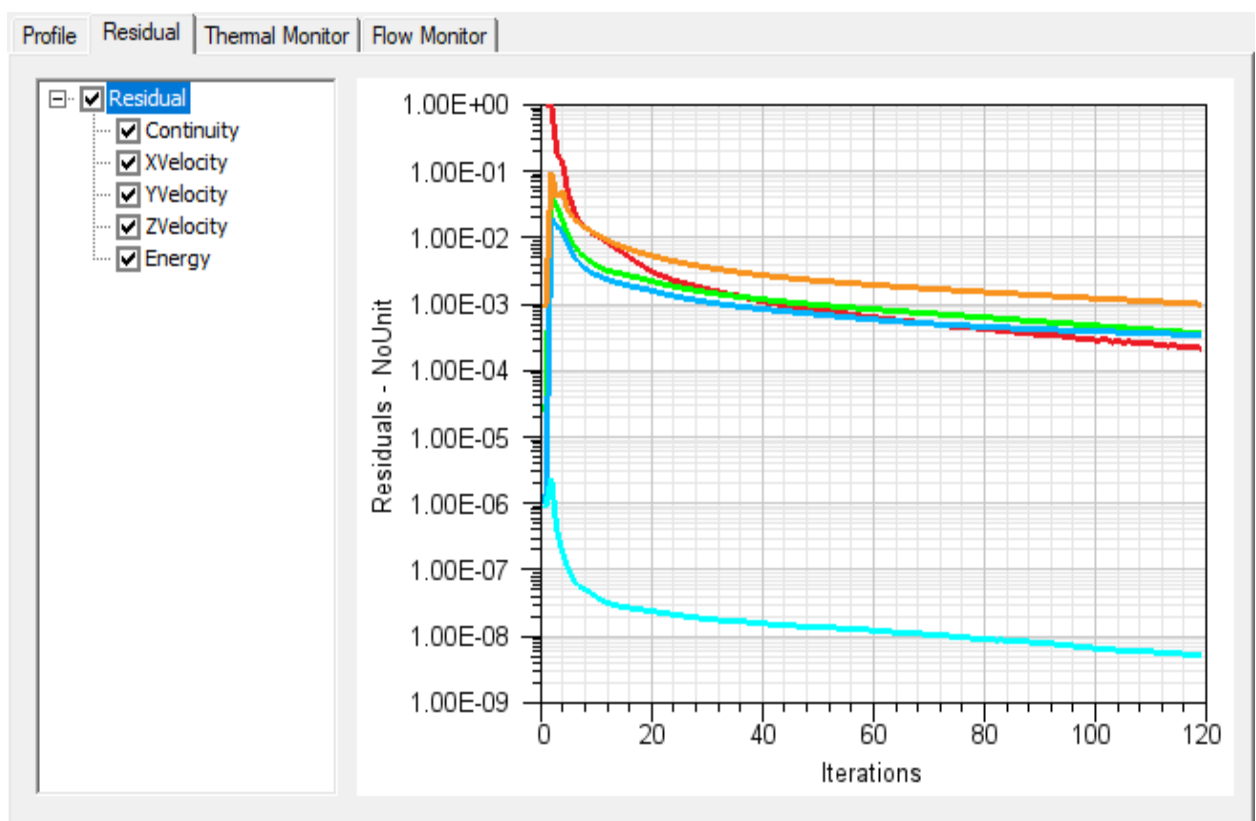

4. Click the **Thermal Monitor** tab to view the temperature data for the monitor point on the

source.

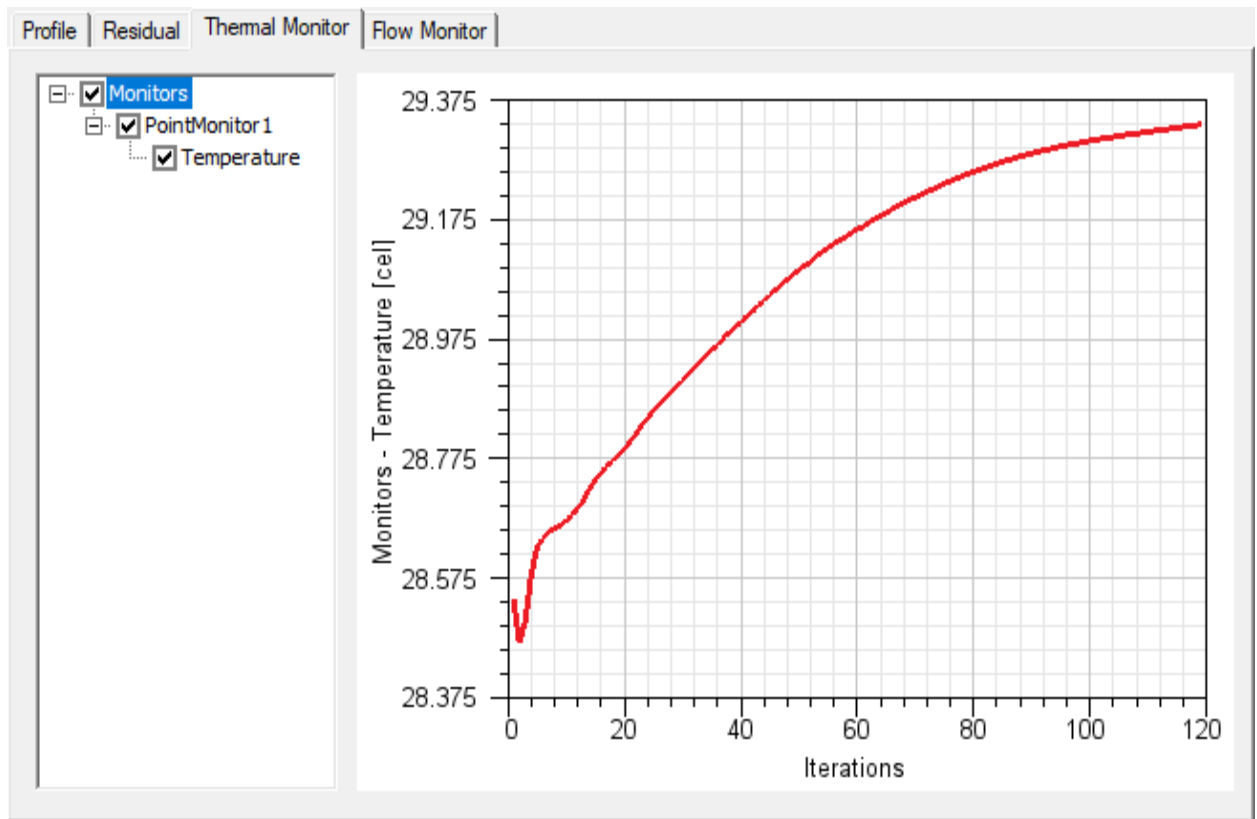

Examine the Results

1. On the **Results** ribbon tab, click **Fields Summary**.
2. In the **Fields Summary** dialog box, the data is updated with the new solution data. Note that the maximum temperatures for both objects are very close to those obtained in the

simulation with the conformal mesh.

Fields Summary: NonConformalMesh - Non-ConformalMesh

Inputs

Solution: Setup1 : SteadyState

Design Variation: Nominal

Calculations:

Entity Type	Geometry Type	Entity	Quantity	Side	Normal	Mesh	Min	Max	Mean	Stdev	Area/Volume	
Object	Surface	source_1	Temperature[C]	Default	-0.00,1.00,-0.00	Reduced	28.3367	29.3323	28.9306	0.24111	0.0016 m ²	Setup...
Object	Surface	Heatsink1_Base,Heatsink1...	Temperature[C]	Default		Reduced	22.4655	29.1125	26.2582	1.02086	0.18752 m ²	Delete

Apply and Export... OK Cancel

11 - Summary

In this tutorial, you generated both a conformal and a non-conformal mesh for a simple source-heatsink geometry and compared the two sets of results. You found a reduction in the number of cells for the non-conformal mesh with a negligible change in the temperature data. In the process, you learned how to create a mesh region with slack values to create an appropriate bounding box for your separately meshed region.

The following are some best practices:

- Reduce mesh counts and consequently decrease run times by creating mesh regions that require a different mesh density. Also select suitable slack values that improve the convergence rate while avoiding mesh bleeding.
- Increase slack values for faces with a wake region if using a mesh region. Do this to capture the wake more accurately.
- Create monitor points of relevant quantities (temperature, pressure, or velocity) to help judge convergence alongside residuals.
- Initialize the solution with reasonable values to achieve faster convergence.